



INTRODUCTION

ESOTERIC releases the K-01, the flagship model of our all-in-one advanced D/A converter and Super Audio CD/CD player series, capitalizing on ESOTERIC's state-of-the-art technology and derived from our award winning P-01/D-01 series separates. It has been seven years since the debut of the original X-01, with its high-precision and high-rigidity VRDS-NEO SACD/CD transport mechanism. The X-01/X-03 series, which have stayed at the top of ESOTERIC's all-in-one SACD/CD player lineup, have been completely updated and make their debut as the all-new "K" series in November 2010.

The design concept of the K series is extremely clear and simple -- a 2-channel D/A converter and stereo player that gives a stress-free musical experience, without adding or removing anything from the original source material. All aspects of the design and engineering process for the K series had extremely tough requirements to further advance ESOTERIC's top technology. Design and engineering was completed applying all of ESOTERIC's know-how in mechatronics technology, state-of-the-art audio technology, and evolutionary materials including DAC implementation, for which cost was not a consideration. The K series is committed to advancing the "state of the art" for the 2 channel audio purist, for both high resolution audio files and disc based audio playback applications.

The K-03 is equipped with our new VRDS-NEO "VMK-3.5-10" mechanism, which has further advanced substantially beyond existing VRDS models, and a dual mono configuration of 32-bit monaural D/A converters with four parallel/differential DAC circuits per channel. The analog audio circuit has a separate power transformer. The on-board high-precision clocking circuit has also been advanced. Three sets of 192 kHz/24-bit digital inputs supporting the most advanced high-sampling digital sources are also built-in. USB driver software supports 192 kHz/24-bit asynchronous transmission for connecting with a PC.

The K-03 is a high performance model that follows the philosophy of the top-end all-in-one K-01 digital source, 2-channel playback device.



FEATURES

VRDS-NEO “VMK-3.5-10” transport mechanism

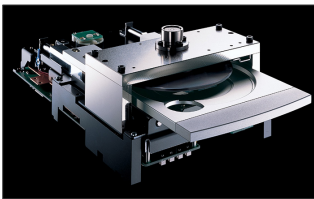

ESOTERIC's proprietary VRDS-NEO transport mechanism uses a high-precision turntable for spinning Super Audio CD/CD discs, improving read precision by mechanically correcting for surface run-out.

This is a comprehensive compilation of ESOTERIC's high-end mechatronics technology. The K-03 uses an evolutionary version of the mechanism configuration adopted for the X-03SE SACD/CD player and now includes the VRDS-NEO “VMK-3.5-10.” This new VRDS mechanism includes further refinements in the design of the driver circuit. The all-new driver circuit specifically for SACDs and CDs, enables smooth, high-precision servo control. A duralumin turntable with micron-level accuracy and a 10 mm steel turntable bridge are used, resulting in a total weight of 4.4 kg (9.7lbs). Additionally, the proven features of the VRDS-NEO, such as the strong neodymium-magnet-driven coreless three-phase brushless spindle motor, the thread feed control, (which has evolved from the philosophy of the P-0), and the shaft-sliding type pickup, where the laser beam consistently illuminates the disk perpendicularly, are all inherited by the K-03.

Dual mono D/A converters based on the philosophy of the K-01

The K-03's D/A converter circuits are based on the circuitry of the ESOTERIC K-01, providing a parallel/differential output with four circuits per channel. This achieves overwhelming linearity and an ultra low distortion factor.

For the D/A converter device itself, ASAHI KASEI Microdevices Corporation's top-end 32-bit AK4399 (*1) was adopted, after extended repetitive audio and system reliability auditions. The 32-bit AKM D/A converters, with four circuits per channel, are mounted on a separate analog audio board for each of the left and right channels and configured for dual mono operation with the same layout for each of the two channels.

The power supply has toroidal transformers specifically used for the analog audio circuits. The transformers boast an ideal power supply capacity with a power supply that is separate from the transport power supply and excellent channel separation achieved through a power configuration separated into right and left channels, to enable high-quality playback with rich localization and sonic depth.

High-quality discrete buffer circuit with a high voltage power supply



A discrete buffer output circuit with a high voltage power supply of +/- 22 V has been deployed for the analog audio output, following the technology used in the D-01. Full use is made of the exceedingly high drive capability and slew rate to

provide a stress-free playback capability for various signals, from minuscule signals to high-power output. These powerful discrete buffer output circuits are laid out symmetrically for each of the hot/cold signal lines to construct a rich and fully balanced configuration for XLR audio outputs. Additionally, a parallel buffer output configuration is implemented to switch the buffer amplifier to a parallel configuration, when RCA audio outputs are used. These enhancements provide advanced circuitry with the best sound quality for each of the balanced and unbalanced signal outputs.

Wide variety of D/D conversion functions that support many source types

A wide variety of D/D conversion functions are implemented to match to your favorite source or to your personal sound quality preference. These functions include a mode to convert DSD and PCM formats directly into analog signals, as well as PCM up-conversion to x 2 (64/88.2/96 kHz) or x 4 (128/176.4/192 kHz), from the original sampling frequency, and even a PCM to DSD conversion function is available.

1. PCM signals from CD and/or external digital devices:
 - Original Fs (32/44.1/48/88.2/96/176.4/192 kHz)
 - x 2 (64/88.2/96 kHz) / x 4 (128/176.4/192 kHz) up-conversion
 - PCM to DSD conversion
2. SACD DSD signals:
 - DSD native playback

Four types of digital filters and digital filter “Off” mode

The K-03 features four types of digital filters for PCM signal processing. In addition to two types of FIR digital filters that have a reputation for outstanding sound quality, two types of short delay digital filters are featured. These filters, often referred to as apodizing filters, eliminate the pre-echo and ringing effects in the impulse waveform to reproduce the audio signal as a more nature and precise sound, void of the artifacts often associated with CD recording. The Digital Filter Off mode, which bypasses all 4 of the digital filters, is also provided. You can select any of the digital filters or the off mode according to your preference.

Three digital input systems to support a high sampling rate

Even when you use the K-03 as a discrete D/A converter for a high-sampling-rate source, the K-03 makes the most of the astonishing quality of its 32-bit dual mono D/A converters. The K-01 features three systems of input (USB, coaxial and optical), and these digital inputs support high-sampling-rate sources up to 24 bit/192 kHz.

USB input supporting asynchronous transmission and 24 bit/192 kHz sources enables high-quality reproduction of music stored on a PC



High-sampling-rate sources of studio master quality can be input at their original resolution, by connecting the K-03 to your PC through a USB port. To ensure a precise high-end design for the USB connection, ESOTERIC developed

proprietary driver software (the driver software can be downloaded from the ESOTERIC web site). The USB input supports high-quality asynchronous transmission and the input of high-sampling-rate sources up to 24 bit / 192 kHz. Three transmission modes, including two types of high-speed transmission (including asynchronous transmission), and the standard full-speed mode, are also provided to enhance compatibility with a wide variety of PCs and operating systems. Additionally, an Esoteric USB isolator, isolates the power and signal paths from the USB input system. This isolator eliminates interference from external devices, including the PC, to clearly reproduce high-resolution music files without loss of fidelity.

* Note: Reproducible formats depend on the music player capabilities installed on the PC.

(*1) AK4399 is the Audio4pro™ and is a branded product of ASAHI KASEI MICRODEVICES CORPORATION that is designed for professional studio and digital audio applications.



VCXO high-precision clock

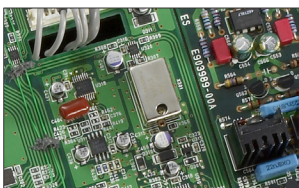

A newly designed high-precision clock is implemented to achieve the highest level of sound quality for an all-in-one digital player. A VCXO (voltage controlled crystal oscillator) of ± 0.5 ppm (*2) that uses a large crystal is deployed in the K-03, which is

very advantageous for advanced sound quality.

Additionally, a stabilized power supply circuit improves the stability of clock circuit operation. When using the K-01 without using an external WORD clock, the high precision audio clock sync signal generated by the VCXO is directly delivered to the D/A converter, without passing through the PLL circuit. This enables higher-quality reproduction that is a step ahead of standard designs. This also substantially reduces any audible jitter when transmitting audio signals to achieve high-speed and high-quality reproduction inclusive of a very dramatic presence and acoustic delicacy.

(*2) Factory setting

WORD sync function enabling synchronization with external devices

The K-03 has a WORD sync function to synchronize with an external WORD clock. This allows upgrading to a higher-quality sound system by connecting the unit to a high-precision master clock generator, such as the G-0Rb rubidium master clock. As for supported clock sync frequencies, 10 MHz is newly supported in addition to 44.1/88.2/176.4 kHz.

32-bit precision digital attenuator function

This function enables 32-bit digital processing and a high-precision volume control, capitalizing on the 32-bit D/A devices. 32 bits gives an allowance of 8 bits over the standard 24 bits, and enables control of volume with no degradation of sound quality due to dropouts.

Excellent usability

The output voltage of the XLR audio outputs can be switched according to the input sensitivity of the amplifier that you connect to the K-03 (0dB/ +6dB). You can also choose Hot 2 or Hot 3 for the XLR pin assignment. Additionally, you can switch the analog output between RCA, XLR and OFF, as desired based on connected components. The K-03 features one coaxial digital output to support digital output of CDs, and a pass-thru output for an externally input signal; however, digital outputs for SACDs (DSD data streams), and the signal after the D/D conversion are not supported. For noise reduction purposes, it is possible to switch the circuit off when not using the digital output.

Chassis construction with a separate compartment for each circuit block

A chassis construction with separate circuit block compartments packs the design concept of separate SACD/CD transports and D/A converters into an all-in-one unit. This helps to eliminate cross contamination between adjoining circuits. The large-mass VRDS-NEO transport mechanism is positioned in the center of the unit, directly attached to the 5 mm steel bottom chassis, and supported at three points by ESOTERIC's proprietary pinpoint feet (Patent No. 4075477). This 3 point system effectively suppresses the vibration of the rotation mechanism with large inertia to ensure a highly solid base, free from vibrations and resonance.

The interior of the K-03 chassis has a double-decker structure with five compartments. Each circuit block is contained within its own compartment to minimize conflicts between circuits. Two separate audio boards for each channel are mounted on the rear part of the upper compartment, which is nearest to the rear terminals, to ensure the shortest signal path. The audio power circuit and power transformers are isolated from the audio board by an internal steel chassis plate, and hung inside the compartment on the bottom of the audio board. Such a three-dimensional layout allows the shortest wiring possible for the power supply, and minimizes any impact of magnetic flux leakage and vibration.

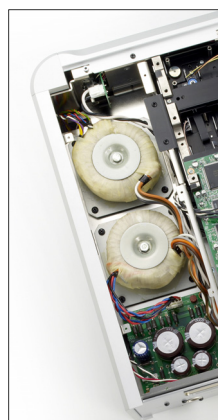

The K-03 features two large-capacity toroidal transformers, including one specifically for the built-in dual mono D/A converters and the audio circuits, and the other for driving the digital circuit and mechanism. This design provides dedicated power supply capability to all circuit blocks without interference.

The K-03's large mass of approximately 28 kg (61.8 lbs), is the result of ESOTERIC's commitment to the highest quality for component isolation and compartmentalizing. These designs virtually eliminate resonance and vibrations from adjacent electrical and mechanical components.

Beautiful rounded form

The K-03 inherits its appearance from the design of ESOTERIC's flagship line of separate digital players and DACs, with the front/side/top panels made of thick aluminum and a rounded form with no screws on the top panel and corners. This form is sure to give you a feel of elegance and pleasure of ownership, in addition to eliminating any unwanted vibrations that are well known from top and corner screw designs.

Feel the high-end touch with a leather finished remote control

The K-03 comes with a remote control unit that is finished in leather and has an aluminum body with just the right weight. The ease of use and accuracy associated with this remote control is also based on ESOTERIC's "P series" system designs.



SPECIFICATIONS

Compatible disc types	Super Audio CD, CD (CD-R/CD-RW compatible)		
Analog audio output	Jacks	XLR jacks (2 channel) x 1 RCA jacks (2 channel) x 1	
	Output impedance	XLR: 100 ohms RCA: 47 ohms	
	Maximum output level (1 kHz, full scale, 10 k ohms)	XLR (Gain: 0 dB): 2.45 Vrms RCA: 2.45 Vrms	
	Frequency response	5 Hz to 55 kHz (3 dB)	
	Signal-to-noise ratio (S/N)	115 dB	
	Total harmonic distortion	0.0015% (1 kHz)	
	Digital audio output	Coaxial RCA jack x 1	0.5 V _{p-p} /75 ohms
Digital audio input	Coaxial RCA terminal x 1	(input impedance 75 ohms)	
	Optical digital terminal x 1	24.0 to 14.5 dBm peak	
	USB port B connector	USB 2.0 / 192 kHz-24 bit async.	
Word synchronization input format	Jack	BNC	
	Input impedance	75 ohms	
	Input level	Rectangle wave: equivalent to TTL levels Sine wave: 0.5 to 1.0 Vrms/50 to 75 ohms	
	The K-03 can accept and synchronize to the following frequencies received from external clock devices: 44.1 kHz, 88.2 kHz, 176.4 kHz, 10 MHz (the accuracy of locking range limited within ±15 ppm)		
D/A Converter	K-03	32bit AK4399 x4 DACs / per channel	
General	Power supply	AC 230 V, 50 Hz	
		AC 120 V, 60 Hz	
		AC 220 V, 60 Hz	
	Power consumption	27 W	
	External dimensions (W x H x D)	445 x 162 x 438 mm (17 1/4" x 6" 3/8 x 13 1/4") (including protrusions)	
	Weight	28 kg (61 3/4 lbs)	
	Accessories	Remote control unit (RC-1156) x 1	
		Batteries (AA) x 2	
		Power cord set x 1	
		Felt pads x 3	
Owner's manual x 1			
Warranty card x 1			

- This product is available in three different power supply variations shown in the chart above. Make sure that the voltage shown on the rear panel matches the AC line voltage in your area.
- The shape of the AC inlet and plug of the supplied power cord depends on the voltage rating and destination country.

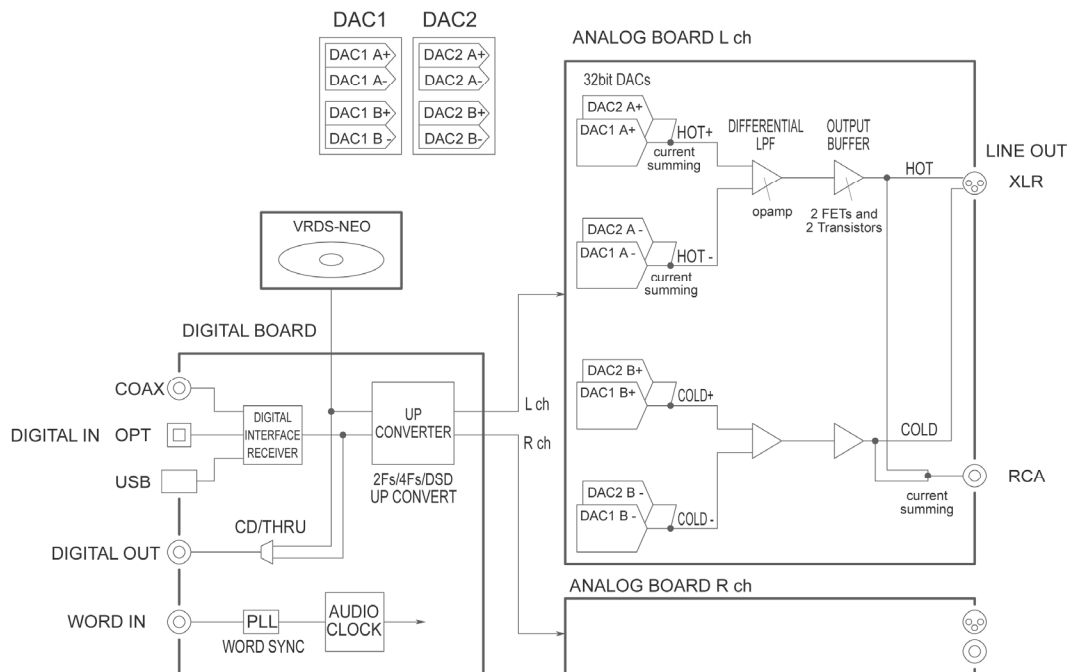

Please note that ESOTERIC products are available at limited retailers in respective countries. "ESOTERIC" is a trademark of the TEAC Corporation. All other brand or product names are trademarks or registered trademarks of their respective holders. ©2010 TEAC Corporation. All Rights Reserved. All text, images, graphics and other materials on this catalogue are subject to the copyright and other intellectual property rights of TEAC Corporation. These materials shall not directly or indirectly be published, reproduced, modified or distributed in any medium. Design and specifications are subject to change without notice.

ESOTERIC COMPANY
 47 Ochiai 1-chome, Tama-shi,
 Tokyo 206-8530, Japan
 Fax: +81-42-356-9240 www.esoteric.jp/
 www.teac.com/esoteric/